

JYHY210000_(2V1000Ah)

GENERAL FEATURES

- Absorbent Glass Mat (AGM) technology for efficient gas recombination of up to 99% and freedom from electrolyte for air transport-complies with LATA/ICAO Special provision A67.
- Not restricted for air transport-complies with LATA/ICAO Special Provision A67.
- UL-recognized component.
- Can be mounted in any orientation.
- Computer designed lead, calcium tin alloy grid for high power density.
- Long service life, float or cyclic applications,
- Maintenance-free operation.
- Low self discharge.
- Case and cover available in both standard and flame retardant ABS.

SPECIFICATION

Nominal voltage	2V	Dimensions	Total Height	14.45inches(367mm)
Rated capacity (10 hour rate)	1000Ah		Height	13.0inches(330mm)
Number of cell	1		Length	18.7inches(475mm)
Approx. Weight (Kg / lbs)	61/134.4		Width	6.89inches(175mm)

Battery Dimensions

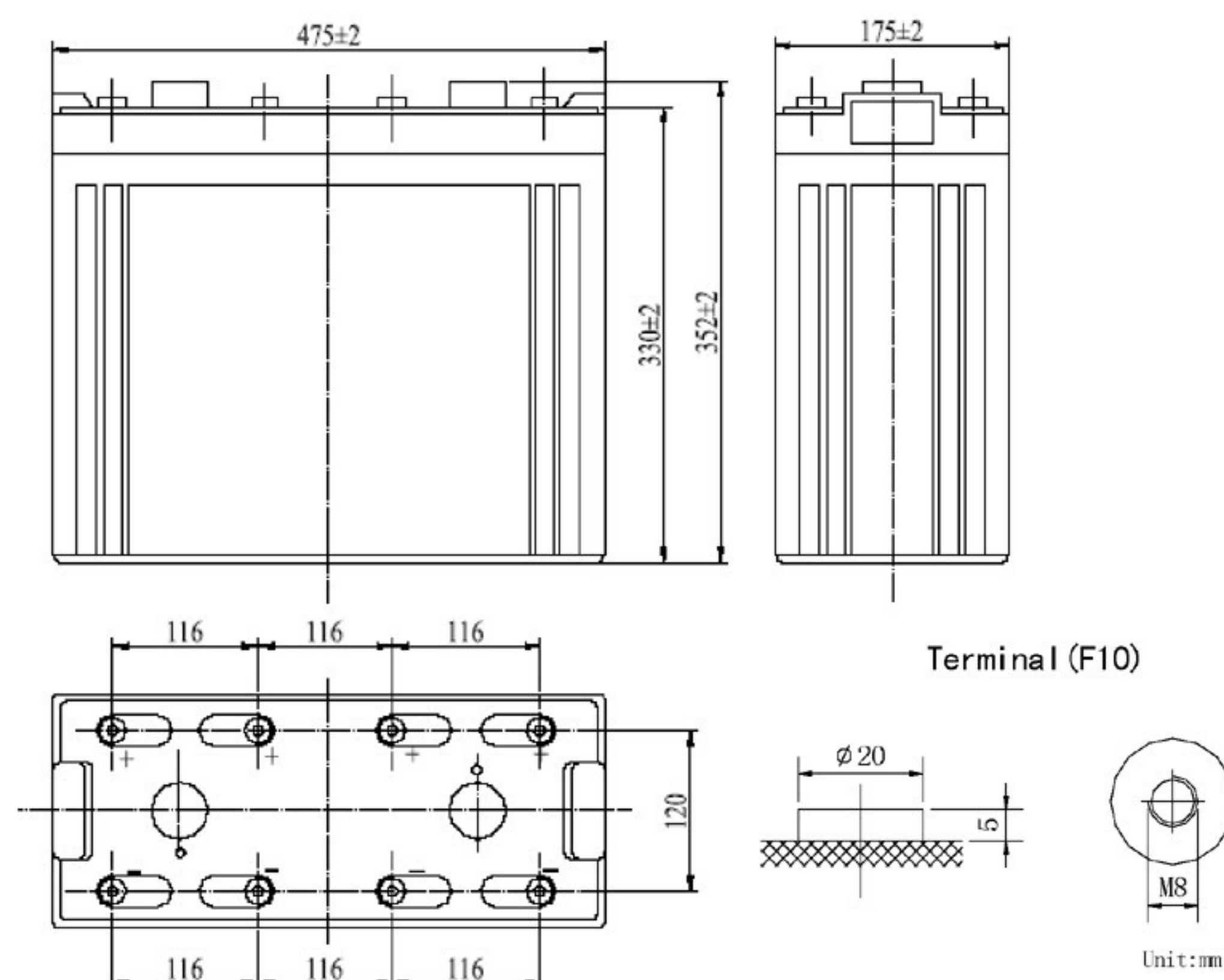

Total height with removable cover: 367

Constant power discharge ratings-watts per cell at 25°C(77° F)

End Point Volts/Cell	5min	10min	15min	30min	45min	1h	2h	3h	5h
1.60V		2965	2421	1804	1360	1114	720	522	360
1.65V		2793	2290	1713	1298	1067	702	507	354
1.70V		2620	2158	1621	1233	1018	688	497	348
1.75V		2447	2024	1527	1166	967	676	488	341
1.80V		2276	1890	1432	1099	915	661	476	335

Characteristic

Capacity 77° F(25°C)	20 hour rate (53A、1.75V)	1060Ah
	10 hour rate (100A、1.75V)	1000Ah
	5 hour rate (175A、1.75V)	875Ah
	3 hour rate (260A、1.70V)	780Ah
	1 hour rate (620A、1.60V)	620Ah
	1C (1000A、1.60V)	32min
Internal Resistance	Full charged Battery 77° F(25°C) : 1m Ω	
Capacity affected by Temperature (20 hour rate)	104° F(40°C)	102%
	77° F(25°C)	100%
	32° F(10°C)	85%
	5° F(-15°C)	65%
Self-Discharge 68° F(20°C)	Capacity after 3 month storage	90%
	Capacity after 6 month storage	80%
	Capacity after 12 month storage	60%
Max. discharge current 77° F(25°C) : 2000A(5S)		
Charge (Constant Voltage)	Float: 2.25~2.30 V/77° F(25°C)	
	Cycle: 2.35~2.45 V/77° F(25°C) Max. Current: 200A	

